



25.0 A Single-Phase Silicon Bridge Rectifier
Rectifier Reverse Voltage 50 to 1000V



Features

- This series is UL listed under the Recognized Component Index, file number E142814
- The plastic material used carries Underwriters Laboratory flammability recognition 94V-0
- Universal 4-way terminals, snap-on, wrap-around, solder or P.C. Board mounting
- Surge overload ratings to 300 amperes
- Electrically isolated metal case for maximum heat dissipation
- Case to terminal isolation voltage 2500V

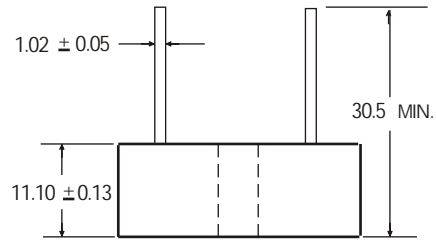
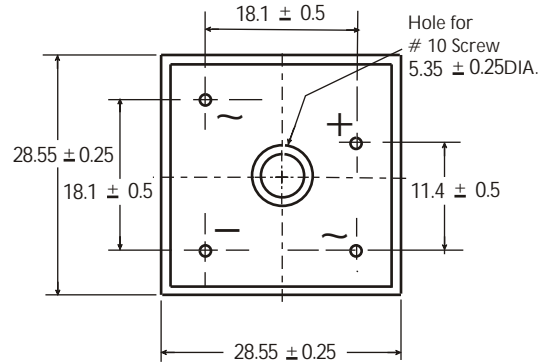

Dimensions in millimeters (1"=0.0394")

Mechanical Data

Case: Metal case
 Terminals: Plated copper leads .04" (1.02 mm) diameter
 Weight: 1.007 ounce, 28.5 grams (approx)
 Mounting Position: Bolt down with silicone thermal compound between bridge and mounting surface for maximum heat transfer efficiency
 Mounting Torque: 20 in-lb max.

Maximum Ratings & Thermal Characteristics

Rating at 25°C ambient temperature unless otherwise specified, Resistive or Inductive load, 60 Hz.
 For Capacitive load derate current by 20%.

| Parameter | Symbol | KBPC25005W | KBPC2501W | KBPC2502W | KBPC2504W | KBPC2506W | KBPC2508W | KBPC2510W | unit |
|---|------------------|--------------|-----------|-----------|-----------|-----------|-----------|-----------|--------------------|
| Maximum repetitive peak reverse voltage | VRRM | 50 | 100 | 200 | 400 | 600 | 800 | 1000 | V |
| Maximum RMS bridge input voltage | VRMS | 35 | 70 | 140 | 280 | 420 | 560 | 700 | v |
| Maximum DC blocking voltage | VDC | 50 | 100 | 200 | 400 | 600 | 800 | 1000 | V |
| Maximum average forward rectified output current at TA=55°C | IF(AV) | 25 | | | | | | | A |
| Peak forward surge current single sine-wave superimposed on rated load (JEDEC Method) | IFSM | 300 | | | | | | | A |
| Rating for fusing (t<8.3ms) | I ² t | 664 | | | | | | | A ² sec |
| Typical thermal resistance per element(1) | ReJA | 2.5 | | | | | | | °C / W |
| Operating junction and storage temperature range | TJ, TSTG | -55 to + 150 | | | | | | | °C |

Electrical Characteristics

Rating at 25°C ambient temperature unless otherwise specified. Resistive or Inductive load, 60Hz.
 For Capacitive load derate by 20 %.

| Parameter | Symbol | KBPC25005W | KBPC2501W | KBPC2502W | KBPC2504W | KBPC2506W | KBPC2508W | KBPC2510W | Unit |
|---|--------|------------|-----------|-----------|-----------|-----------|-----------|-----------|------|
| Maximum instantaneous forward voltage drop per leg at 12.5A | VF | 1.0 | | | | | | | V |
| Maximum DC reverse current at rated DC blocking voltage per element | IR | 10 500 | | | | | | | μA |

Notes: (1)Thermal resistance from Junction to Ambient on P.C.board mounting.



Rating and Characteristic Curves ($T_A=25^{\circ}\text{C}$ Unless otherwise noted)
KBPC25005W thru KBPC2510W

Fig. 1 Derating Curve for Output Rectified Current

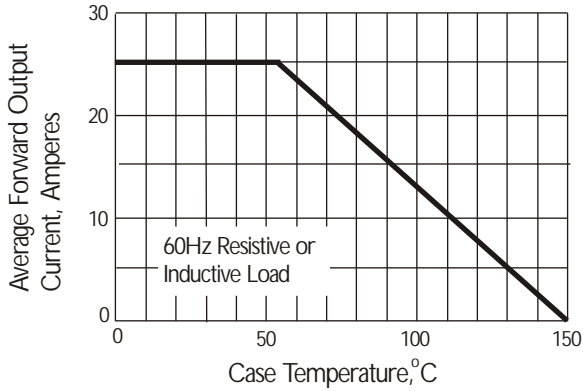

Fig. 2 Maximum Non-repetitive Peak Forward Surge Current

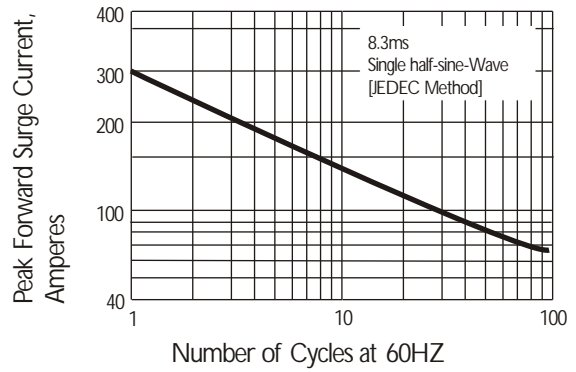

Fig. 3 Typical Instantaneous Forward Characteristics

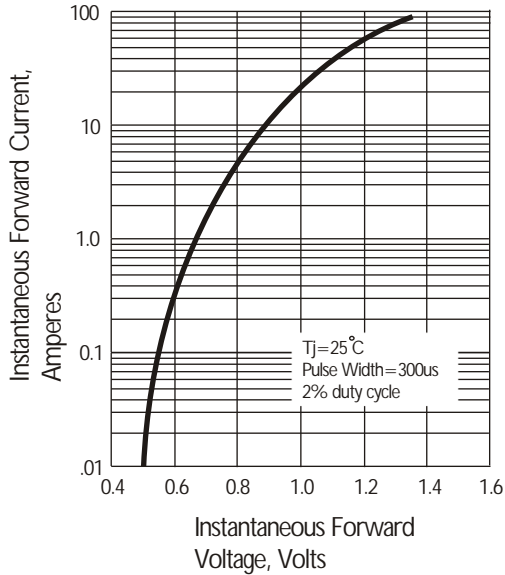

Fig. 4 Typical Reverse Characteristics at $T_J=25^{\circ}\text{C}$

